

Article

Quality and Safety of Extracted Humic Substances as Fundamental Factor of Natural Regulation for the Sustainable Development

Maksym Melnychuk ^{1,3,*}, Oleksii Petrov ², Konstantin Torop ², Igor Jakimenko ², Linjun Xun ³ and Husheng Zhao ^{3,*}

¹ Department of Veterinary medicine, Clinic Diagnostic and Biotechnologies, National Academy of Agrarian Sciences of Ukraine, Vinnytsia National Agrarian University, 21008 Vinnytsia, Ukraine

² Quinta Essential Fabula Prima, Ltd., 20-007 Lublin, Poland; ap@fulvix.life (O.P.); kt@protohumix.com (K.T.); quintaessentiapolska@gmail.com (I.J.)

³ Zhejiang Toyoshima Co., Ltd., Xinchang 312500, China; xlj@fomdas.com

* Correspondence: melnychuk.maks@gmail.com (M.M.); 1908256578@qq.com (H.Z.)

Abstract: Humic substances as natural biogeochemical macromolecules have been formed over tens of millions of years as a result of the processes of natural destruction of biological systems with a high degree of chemical diversity. The prospects and realities of today's use of humic substances by humans in agriculture, pharmaceuticals and medicine raise the issue of strict safety control of various drugs derived from these natural substances. These technologies for the extraction and purification of final humic preparations should be carried out in accordance with the balanced development of natural ecosystems and biosafety requirements. In this publication we raise the issue of creating a single standard for the quality and safety of purified humic substances on a global scale.

Keywords: humic substances; extraction; quality and safety



Citation: Melnychuk, M., Petrov, O., Torop, K., Jakimenko, I., Xun, L., & Zhao, H. (2024). Quality and Safety of Extracted Humic Substances as Fundamental Factor of Natural Regulation for the Sustainable Development.

Agricultural & Rural Studies, 2(3), 12. <https://doi.org/10.59978/ar02030013>

Received: 24 July 2024

Revised: 29 August 2024

Accepted: 4 September 2024

Published: 9 September 2024



Copyright: © 2024 by the authors. Licensee SCC Press, Kowloon, Hong Kong S.A.R., China. This article is an open access article distributed under the terms and conditions of the [Creative Commons Attribution \(CC BY\)](https://creativecommons.org/licenses/by/4.0/) license.

1. Introduction

The global study of humic substances began more than two hundred years ago, in 1786, by F. Ahard, and by the mid-19th century, chemists like Berzelius and Sprengel had begun to study these complex molecules more thoroughly. Humic substances themselves are the “organic origin” (matter) of the aquatic and terrestrial environment. This is a complex dispersed-heterogeneous composition of various organic compounds that are produced by microorganisms as a result of fermentation of residues of organic substances in the medium: soil, bottom sediments of water bodies, or rock. At the same time, scientists classify humic substances (HS) as a supramolecular association of small heterogeneous molecules that are connected by weak intermolecular bonds. HS extracted from soil and water are the most common organic compounds that have arisen in the process of chemical-physical and microbial transformation of biological molecules. In terms of the volume of organic carbon on the planet, they account for about a quarter of the total and account for up to two-thirds of the dissociated organic carbon in water. This situation is considered by many scientists as determining for many ecological and microbiological processes in both soil and water systems (Makan, 2021). It is known that humic substances are complex organic compounds obtained as a result of humification of plant residues as a result of enzymatic transformation by their microorganisms under certain influences of abiotic factors. They are characterized by non-stoichiometric composition, branched structure, their structural elements are heterogeneous and have high poly-disperse properties. They consist of humic, fulvic, and humatmelanic acids each of which has unique properties. Humic acids are characterized by high molecular weight and insoluble in water at low pH while fulvic acids have a lower molecular weight and are soluble in water at any level of acidity, humatmelanic acids are soluble in alkali and alcohol, but insoluble in acid. These compounds are enriched with many functional groups, such as phenols and carboxyl groups, which give them powerful anti-inflammatory, antioxidant, and antimicrobial properties (Figure 1; Chen et al., 2020; Cui et al., 2017).

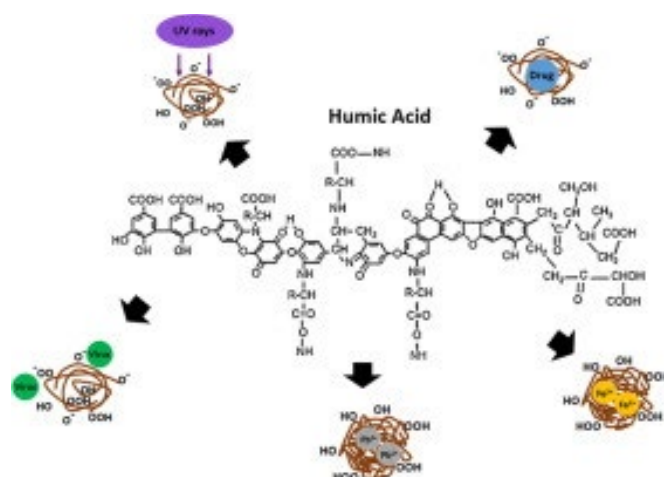

Figure 1. Humic acid composition of phenolic, carboxylic acid, quinone, enolic, and ether functional groups as many peptides and sugars (de Melo et al., 2016).

HS exist naturally in almost all highly viscous media: in soil, Leonardite, brown coal, soil peat, river, lake, and other waters, etc. As a result of their decomposition and enzymatic transformation of animal and plant remains, their formation is explained by several theories. The presence of phenolic-carboxyl groups in their composition is determined by their many properties and, above all, water dissociation and, as a result, the absorption of various cations or mycotoxins. Polyelectrolyte properties determine the high efficiency of HS chelation. A number of scientists have shown the high efficacy of these substances in detoxification, antiviral, anti-inflammatory, and anti-cancer effects. It is shown that in nature scanty amounts of humic substances are contained in standing water, clays, and sandy soils. A little more of them are identified in medical mud, humus, and upper soil layers. The highest content in peat ranges from 10 to 40%, in lignite from about 10–30%, and in brown coals, an average of 40% of the volume. It has been shown that specific substances, called oxyhumolites, are formed from brown coal or lignites when exposed to air and water. They include the largest amount (50–80%) of humic substances (Vašková et al., 2023).

Humic acid (HA) is increasingly attracting attention and is becoming widely used in medical practice, health care, and beauty salons. The definition of “humic acid” is a complex mixture of many quantities of different acids naturally present in soils, rivers, and oceanic waters. Humic acids are almost completely degradable residues of organic life—proteins and amino acids of relict plant and animal organisms. Saprophytic bacteria and fungi enzymatically transform these remnants of flora and fauna in aerobic and anaerobic conditions. At the same time, ammonia is released and some of the protein hydrolysis products can become part of humic molecules. This is due to covalent binding to phenolic or quinone cyclic chains, which has already been noted by a number of research scientists (Stevenson, 1994). It is important to note the cation exchangeability of humic substances. It was also noted about the high water retention capacity. HA perfectly binds insoluble ions of various metals their oxides and hydroxides. Thus, bound ions perfectly make them more accessible to nutrition for plants, for example. This uniqueness of HA has been widely used in recent years in organic farming and serves as a good tool for improving product quality and safety and increasing the number of crops. Such results have been obtained by many scientists including in Nepal, for example. Thus, it is shown that HA significantly increases the production parameters and quantity and quality of agricultural products (Gairhe et al., 2021).

Due to the ever-growing global demand for food production, there is widespread overuse of chemical (mineral) fertilizers. This approach has led to global acidification and deterioration of soils across the planet. Scientists point to immediate action to restore the primacy of agrocenosis and soils. Increasingly it is necessary to use technologies using organic fertilizers such as manure or compost which contain vital substances and compounds for quality plant growth and restoration of soil fertility. The direct use of HS increases the supply of plants with the necessary nutrients. Due to the increased metabolism with such biotechnologies, there is an effect of increased absorption of atmospheric CO₂ due to an increase in the yield of the final biomass of plants and yield. There is a clear conclusion about the need for global promotion and application of HS starting with the cultivation of crops both outdoors and indoors including modern vertical greenhouses. This technology significantly reduces the concentration of CO₂ in the atmosphere and creates sustainable agricultural development (Tiwari et al., 2023).

2. Methodology

Humic acid is not a pure fertilizer and is an effective component to be used as a supplement to mineral or organic fertilizers adjusting their balance and useful properties. Agrotechnologists have proven that regular use of humic acid reduces the need for various fertilizers due to the ability of plants to assimilate them better. In some cases, fertilizer application can be completely excluded with a sufficient amount of organic material. It has been shown that using humic acids improve the soil structure by limiting excessive loss of various substances and water in sandy (light) soils and improving soil aeration and water retention too. This is a great benefit for the environment of the agricultural sector and for producers.

HA perfectly stimulates the activity of the overall growth of plants and microorganisms. It catalyzes many biological processes that contribute to the growth and spread of beneficial microflora of microbial origin in the soil. This clearly increases the natural resistance of plants to diseases and pests. There is an active growth of roots especially vertical roots which ensures better absorption of nutrients and process of transpiration of plants. HA plays a vital role in improving the quality of both yields and their appearance through increased synthesis of vitamins and transport of minerals in plants. This effect is directly related to the regulation of the beneficial bacterial community with plants responsible for the processes of speed and quality of plant growth (da Silva et al., 2021). HA reduces the amount of various soluble salts in soils thereby reducing their likely toxicity. Humic acid reduces the shrinkage of the roots that occurs due to the excessive concentration of salt in the soils after fertilization. By increasing the ability of soil colloids to group it improves the root system as a whole and plant development. Humic acid also chelates nutrients especially iron which as a result becomes more available to the plant. It was shown that it's possible to achieve an increase in yield of up to 70% with a parallel reduction of up to 30% in the use of fertilizers and pesticides while having a healthier growth of green mass for both ornamental crops and agricultural and forest park crops. It can be achieved with the regular use of high-quality humic preparations. Same time soil water retention increases significantly which leads to a significant reduction in water use. Thus, it should be noted that clarifying and encouraging farmers to use HS worldwide can also help reduce the concentration of CO₂ in the atmosphere and create a sustainable development of the ecosystem anywhere in the world (Tiwari et al., 2023).

It is already known that the excessive use of mineral fertilizers in agriculture in recent decades has had a detrimental effect on soil properties, especially in terms of reducing biodiversity, organic substances, and especially soil microbiological activity. Excessive use of fertilizers has also increased the risks of almost complete loss of nutrients due to soil leaching. The drainage of groundwater or surface runoff is also disrupted which poses a significant threat to the planet's environment on a national scale. In addition, high levels of fertilizer use can cause an imbalance in the availability of nutrients in the soil, which leads to low nutrient efficiency and metabolic changes. This is due to the fact that plants are not able to adequately absorb and use the absorbed nutrients for their intended purpose. Many effects in plants induced by HA depend on their molecular structure as evidenced by induced molecular structural modifications and their interactions with roots. Root exudates can change the molecular conformation and properties of HS (Nardi et al., 2024). It was also experimentally revealed that it is the physiologically active forms of humic acids that have trigger properties. Thus, physiological forms of humic acids contribute to the launch of a protein synthesis system that responds to adverse growth conditions. In addition, humic acid increases the photosynthetic activity of the plant and also increases the activity of the Rubisco enzyme. Humic substances have an anti-stress effect in conditions of non-living stress. These substances can also increase nutrient absorption and reduce the toxicity of some absorbed elements. Therefore, the use of humic substances when plants are exposed to salinity stress can lead to improved plant growth. In addition, humic acid affects the activity of plant enzymes (Hassan et al., 2023; Khalate et al., 2023).

Many scientists and biotechnology producers consider the process of extraction and purifying HS for further use in various areas—agriculture, animal husbandry, and for humans in various aspects. Based on the tasks set we propose to consider the basic existing principles of obtaining products for agricultural and human usage which could be officially recognized and validated today. It has been well known a number of methods for extracting humic substances, for example, from soil using soft alkaline extraction. All these methods are generally successful and give quite comparable results. However, the extraction method proposed by the International Society of Humic Substances (IHSS) is accepted worldwide as a method of extracting humic substances from soils (Aiken et al., 1985). Nowadays humic acid preparations are available from many manufacturers or specialized supplier companies in the world which are represented by many different types of products such as granules, powder, liquid, and flakes. This is determined depending on the technique of application to the soil, foliar application, seed treatment, drip irrigation, or application simultaneously with mineral fertilizers. It has been shown that the best economic results using HS can be obtained in light and sandy soils with poor humus as well as in reclamation fields. This is typical for almost all

soils in dry and hot regions of the planet. As a result of the high rate of mineralization of organic substances that provide these soils with stable humic acids, this factor is indispensable for maintaining and improving soil fertility. The combined use of HS and mineral fertilizers alleviates the problems associated with continuous cropping systems. With HS the number of basic macronutrients (nitrogen, phosphorus, and potassium) and organic matter in the soil available to plants increases resulting in an increased uptake of macronutrients by plants. Various HS salts such as potassium and calcium humate are used as fertilizer additives to increase soil fertility. Increasing the level of natural HS such as potassium humate reduces the need for commercial fertilizers as it improves soil fertility (Karčauskienė et al., 2019; Niewes et al., 2023).

The HA production and purification process is based on the elimination of insoluble humic microparticles from products after alkaline extraction with subsequent deposition of soluble humates. To do this the following acid extraction procedure is performed. The resulting deposited elements (sediment) are cleaned to produce HA. It should be noted that fulvic acids (FA) are concentrated as soluble compounds in an acidic solution. The authors of the technologies proposed to separate humins from soluble alkaline extracts by filter pressing and subsequent centrifugation (Yan et al., 2021). Along with the quality of alkali purification of humates, it is necessary to determine the quality of separation of humins and inorganic impurities. It is this process that determines the qualitative properties of the obtained HA. Due to the wide use of HA in agriculture and especially in medicine such production requires high purity and quality of the product. This requires new and high-quality methods of separation and cleaning. Membrane filtration technology has been shown to be an effective way to reduce the ash content in the final product which allows it to be used for medical purposes. Membrane separation can also improve the water solubility of HA by changing their molecular distribution and removing various inorganic elements (Novák et al., 2001). Although membrane-based separation methods are quite effective and environmentally balanced technologies.

It is noted that there is critically little research to optimize the operating parameters for membrane purification of a humic substance from an alkaline extract based on lignite. Scientists and technologists set a number of tasks to develop a perfect membrane system for the separation and purification of HA from humate retentates obtained as a result of the alkaline extraction process. It was noted that HA showed a certain dispersion between the original coals. While the final yield, molecular weight and amount of oxygen-containing HA groups increased in hydrogen peroxidized coals. It was also noted that the increase in the number of oxygen-containing functional groups depended on the quality of the original coals. The final HA yield depends on the quality of coal production and processing and not on the percentage. The final HA capacity from the original coal compared to the oxidized coal increases significantly from 17.47% to 40.03% (Sarłaki et al., 2019).

It is known that for the deposition of humic acids, they should be cleaned in an alkaline environment. The maximum HA capacity (90.2%) was obtained from the 0.250–0.180 mm size fraction of the coal sample at a reaction temperature and time of 190 °C and 7 h. Proximate analysis proved that the ash and sulfur of lignite can be removed by hydrothermal treatment. Elemental analysis showed that the O/C and H/C ratios were the highest for HA. For residual and raw coals indicates an increase in the content of oxygen and hydrogen in HA. Analytical studies have shown that hydrothermal extraction destroys the macromolecular structure of lignite and during the reaction organic substances are degraded and hydrolyzed (Cheng et al., 2019). Quite recently have shown several approaches to extract HA from lignite—physical, chemical alkaline and acidic as well as biological methods (Jaing et al., 2011).

HA extraction from Bulgarian lignite using NaOH dissolution and HCl sediment was also described. At the same time final product with 83% HA content was obtained at the output. Also, South Moravian lignite with the addition of NaOH (0.5 mol/l) and Na₄P₂O₇ (0.1 mol/l) solution with the subsequent addition of 0.5% HCl - HF solution (Stefanova et al., 2016). The method of extraction of HA by oxidation of H₂O₂/HNO₃ is also described (Cihlář et al., 2014). The production of water-soluble polycondensate which had similarities to humic acid, and which simulates the fundamental physico-chemical and spectroscopic properties of natural HA (Drosos et al., 2011) is described. It is also possible to extract HA dissolved in water as well as in a melanin-like polymer complex from wastewater using ammonium sulfate as a natural additive (Khemakhem et al., 2016).

3. Results and Discussion

Humic acids from young brown coals (leonardites) are about 55,000,000 years old from many sources located in Eastern and Western Europe, Asia, China, Canada, and the USA. It is a fossil with global reserves of trillions of tons the efficiency of which is extremely low when used in the energy sector. Leonardites have high humidity and a quite low combustion point and significant atmospheric emissions from their combustion from year to year reduce their global industrial consumption. At the same time, brown coal is a natural treasury containing almost all chemical elements including precious and rare earth metals, essential amino acids, and trace elements, without

which no cell organism can develop. For many decades humanity has been in constant search for how to properly use this significant natural resource. There are several issues and obstacles along the way and the main ones are the cost of extracting elements useful for humanity and their subsequent purification of all foreign impurities such as accumulated radionuclides, heavy metals, chlorides, and other toxic and dangerous elements. For tens of millions of years, the formation of coal seams has simultaneously created an almost indestructible molecular bond of carbon with substances that are not always useful not for the environment neither for the soil nor for plants, and of course not for human consumption. Obviously, there have been many attempts to compile molecular formulas for humic substances in the history of science and technology. Nowadays there are dozens of such formulas and some of them only as flowcharts and others that more or less truly reflect the composition and properties of humic and fulvic acids.

Our innovative technology makes it possible to process natural brown coal, leonardite, etc. into high-purity organic biostimulants of the humic-fulvic type. At the end of process final products are free of heavy metals, radionuclides, toxic elements, and other impurities. The method we have taken as a technological basis allows us to clean highly viscous media at the stage of their extraction, during the processing taking place inside the mechano-chemical reactor invented. It carries out acidification processes with the formation of humic acid released from a liquid phase into a heavy phase of a coagulated pulp, carrying out mechanical phase separation processes in a centrifugal field, carrying out liquid-phase mechano-activation and the dispersion of reaction compositions via grinding, using residual “water” in recycling, and including the production of pure water-soluble humic acids and fuel briquettes, as well as allowing for the production of a wide range of vital and useful products (Figure 2).

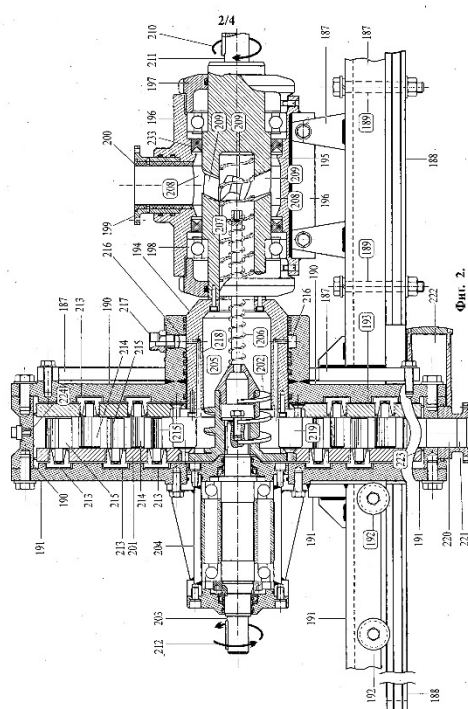

Figure 2. Scheme of the ProtoHumiX® mechanochemical reactor for processing highly viscous media according to Patent WO 2015163785 (Sevast'yanov et al., 2015) implemented in 42 countries.

The extracted substances are directly involved in the metabolic processes of plants, animals, and humans and thanks to their highest ecological purity they offer huge benefits for the health of species. Humic acids extracted from leonardites in accordance with our patented technology are 100% organic in nature, i.e. they have no analogues and cannot be laboratory synthesized as there are no exact molecular formulas for them. The main characteristics of the products that we receive when implementing our patented technology are as follows:

- the highest degree of purification (complete absence of harmful and potentially harmful impurities inherent in all extracts from highly viscosity media), which makes it possible to be used not only in the field of organic farming but also in animal husbandry, poultry, fishery, including for human use.
- the concentration of free active water-soluble humic acids (including fulvic, humatomelan, and ulmic groups) is at the level of extract concentration (i.e., at a concentration of 10% humic

- acids in a solution with about 10% free active water-soluble fractions); therefore, the effectiveness of ProtoHumiX® is many times more effective than any other extracts.
- the technology (unlike the existing ones) allows for the maximum possible extraction of humic acids from highly viscous raw materials.
 - it allows to obtain an extract of the final product—the ProtoHumiX® humic acid complex—and the use of which does not prevent fine spraying (does not clog the nozzles of irrigation machines).
 - ProtoHumiX® production is protected at the State level by patent protection in 42 countries worldwide both by technology (production method) and by technological equipment.
 - Regardless of the territoriality of production, ProtoHumiX® is produced within the framework of a single technology and a single Pan-European (TM “Quinta Essentia”), Chinese, Kazakh, and other trademarks (Figure 3).



Figure 3. Dietary supplement “Quinta Essentia” TERRA for human consumption.

Over the past 7 years, international comprehensive and practical studies have been conducted in the field of impact and improving the efficiency of the use of humic substances in agriculture, animal husbandry, and human use. All products for agriculture and food additives for humans are certified in the European Union and are impressed with their functionality, quality, and safety. During 2023–2024 it has been shown that ProtoHumiX® in plant crop production accelerates seedling germination and contributes to the development of a powerful root system of Chrysanthemum plants. The cuttings (seedlings) were soaked for 60 minutes in water solution of ProtoHumix® and sprayed one time after rooting with a working solution of 0.2 g/l of water (without Cl). The second spraying of plants was carried out during the beginning of budding. Third spraying is carried out normally before flowers starting to bloom (Figure 4).



Figure 4. Chrysanthemum roots system development. 1: control plant; 2: ProtoHumix® treated. Picture on 52 days of cultivation.

Our investigations showed that humic substances can only be obtained by extraction from target-relevant sources and can be further purified to obtain a substance of pharmacological (reference) purity $\geq 95\%$ (or not to be purified at all and can be used subsequently in various sectors of the farming, industrial sectors and human use; Tables 1, 2).

Table 1. Quality and safety indicators of ProtoHumiX®, solid.

Nº	Parameter	Result 1	Method 1	Permissible residual amounts, EU Directive 90/496/EEC, nutrition and health claims made on foods
0	Lignosulphonates, %	nil	ISO 19822:2018	-
1	Total content of organic acids, (humic, fulvic, ulmic, humatomelanic), m/m %	58,0	calculation	-
2	Humic substance, m/m %	39,2	ISO 19822:2018	-
3	Ash free humic acids, (at low pH values), m/m %	28,9	ISO 19822:2018	-
4	The content of free water-soluble humic acids, (regardless of the pH value), m/m %	24,9	ISO 19822:2018	-
5	Content of ulmic acids, m/m %	2,0	Alcohol extraction Gravimetric	-
6	Content of humatomelanic acids, m/m %	2,0	Alcohol extraction Gravimetric	-
7	Fulvic acid fraction, m/m %	43,6	ISO 19822:2018	-

Table 1. Cont.

№	Parameter	Result 1	Method 1	Permissible residual amounts, EU Directive 90/496/EEC, nutrition and health claims made on foods
8	Moisture contents (water-soluble), m/m %	8,4	ISO 19822:2018	-
9	The content of dry matter, m/m %	91,6	ISO 19822:2018	-
10	Total Mineral matter water-soluble, (ash), m/m %	33,6	ISO 19822:2018	-
11	pH	8,9	ASTM E70	-
12	Cadmium content as Cd, mg/kg	<0,1	AOAC 965.09	0,2
13	Lead content as Pb, mg/kg	0,2	AOAC 965.09	2,0
14	Mercury content as Hg, µg /kg	<20	AOAC 971.21	<100
15	Arsenic content as As, mg/kg	<0,5	AOAC 965.09	1,0
16	Specific effective activity, Cs ¹³⁷ , Bq/kg	<0,2	AOAC 973.67	> 2 x 10 ⁻¹⁰
17	Specific effective activity, Sr ⁹⁰ , Bq/kg	<0,5	AOAC 973.67	> 2 x 10 ⁻¹⁰
18	Effective specific activity of technogenic radionuclides, Bq/kg	<1	calculation	-
19	Specific effective activity, Ra ²²⁶ , Bq/kg	7,8	AOAC 973.67	> 2 x 10 ⁻¹⁰
20	Specific effective activity, Th ²³² , Bq/kg	14,2	AOAC 973.67	> 2 x 10 ⁻¹⁰
21	Specific effective activity, K ⁴⁰ , Bq/kg	28	AOAC 973.67	> 2 x 10 ⁻¹⁰
22	Effective specific activity of natural radionuclides, Bq/kg	55,2	calculation	-
23	Hard particles content, %/mkm	<0,1/2	Membrane filtration	-
24	Chlorides as Cl, m/m %	0,01	GOST 10671.7	0,05

Table 2. Quality and safety indicators of ProtoHumiX[®], liquid.

№	Parameter	Result 1	Method 1	Result 2	Method 2
0	Lignosulfonates	nil	ISO 19822:2018	-	-
1	Total content of organic acids, (humic, fulvic, ulmic, hymatomelanic), m/m %	15,5	calculation	11,3	Lamar method
2	Content of humic acids, m/m %	10,0	ISO 19822:2018	8,6	Lamar method
3	The content of “bound” humic acids, (at low pH values), m/m %	8,0	calculation	6,6	calculation
4	The content of free water-soluble humic acids, (regardless of the pH value), m/m %	8,0	ISO 19822:2018	6,6	Lamar method
5	Content of ulmic acids, m/m %	2,0	Alcohol extraction Gravimetric	2,0	Methanol extraction & Gravimetric
6	Content of hymatomelanic acids, m/m %	2,0	Alcohol extraction Gravimetric	2,0	Methanol extraction & Gravimetric
7	Fulvic acid content, m/m %	6,0	ISO 19822:2018	2,7	Lamar method
8	Moisture contents, m/m %	84,0	ISO 19822:2018	84,0	Lamar method
9	The content of “dry” substances in the product, minus moisture , (soluble substances and ash), m/m %	16,0	ISO 19822:2018	16,0	Lamar method
10	Mineral content, (ash), m/m %	4,2	ISO 19822:2018	4,2	Lamar method
11	pH	8,6	ASTM E70	8,6	Lamar method
12	Cadmium content as Cd, mg/kg	-	-	<0,1	AOAC 965.09
13	Lead content as Pb, mg/kg	-	-	0,14	AOAC 965.09
14	Mercury content as Hg, mg/kg	-	-	<0,02	AOAC 971.21
15	Arsenic content as As, mg/kg	-	-	<0,5	AOAC 965.09
16	Specific effective activity, Cs ¹³⁷ , Bq/kg	-	-	<0,2	AOAC 973.67
17	Specific effective activity, Sr ⁹⁰ , Bq/kg	-	-	<0,5	AOAC 973.67
18	Effective specific activity of technogenic radionuclides, Bq/kg	-	-	<1	calculation
19	Specific effective activity, Ra ²²⁶ , Bq/kg	-	-	5,5	AOAC 973.67
20	Specific effective activity, Th ²³² , Bq/kg	-	-	8,6	AOAC 973.67
21	Specific effective activity, K ⁴⁰ , Bq/kg	-	-	12	AOAC 973.67
22	Effective specific activity of natural radionuclides, Bq/kg	-	-	17,7	calculation

Table 2. Cont.

No	Parameter	Result 1	Method 1	Result 2	Method 2
23	The content of solid, (ballast) particles in the product for seed soaking technologies, watering and spraying plants, %/mkm	-	-	<0,1/1	Membrane filtration
24	Chlorides as Cl, m/m %	-	-	0,01	GOST 10671.7

The purity has to be confirmed by spectrometric tests and this is the most important quality parameter for humic substances and must strictly comply with the quality and safety of the final products.

4. Conclusions

Based on absolute fundamental and practical conclusions, in our opinion, scientists and especially manufacturers of humic substances around the world should unambiguously understand the importance of this technology and using humic products in many aspects. In times of global warming, soil erosion, destructive wars in Europe, Africa, and the Middle East, pollution and removal of suitable land from agricultural circulation, and a constant increase in the world's population, we face a global responsibility to continue life and solve problems with providing people with sufficient quantity, quality, and safety of food.

Therefore, we bring to the general discussion the issues of quality and safety control in the receipt and implementation of the use of drugs obtained from humic substances - primarily humic and fulvic acids. It is their technological quality that should be strictly unified and comply with the adopted Pan-European standards governing the production of humic acid substances and bio-stimulators, in accordance with Regulation (EU) 2019/1009 of the European Parliament and of the Council of 5 June 2019, laying down rules on the making available on the market of EU fertilizing products, and amending Regulations (EC) No 1069/2009 and (EC) No 1107/2009, and repealing Regulation (EC) No 2003/2003 ([Regulation \(EU\) 2019/1009, 2019](#)).

Systematization and strict control of quality and safety at the legislative level with many quantitative and qualitative indicators will prevent the negative consequences of the use of non-certified (not corresponding to quality parameters) products, the use of which in one hundred percent of cases has an extremely negative impact on ecosystems, soils, ground water first of all. Due to the not rarely uncontrolled use of humic substances (not purified from heavy metals and other xenobiotics, for example), we expose not only agroecosystems to all sorts of risks but also all subsequent tropical chains of planet Earth, from microorganisms, plants, and animals to the top of the food chain—humans!

Global legislative regulation of the production and use of high-quality and safe humic drugs for various purposes will allow the state levels of the countries of the world to solve important and urgent environmental problems in harmony with great economic benefits such as:

- increasing soil fertility and creation of artificial soils.
- detoxification (phytoremediation) of agrocenoses.
- increasing the qualitative and quantitative indicators of yield and the final cost of various crops and vegetables.
- reducing the nation's health spending.
- reduction of consumption and savings on the use of mineral fertilizers and pesticides.
- significant improvement in the environment of states and significant economic benefits.

We focus on the need for strict adherence to and continuous improvement of technologies for the production (extraction and purification) of high-quality final products of humic substances in accordance with the sustainable development of ecosystems and strict compliance with biosafety requirements. Due to the presence on the world market of a fairly large number of low-quality products called "humic acids," the latter can potentially damage the ecosystems of all living organisms including humans. Moreover, this kind of product discredits the technology itself and outstanding manufacturers on a global scale. We stress to focus on creating a single world standard for the quality and safety of extracted and purified humic substances with a view to their widespread use in many aspects of life on planet Earth.

CRedit Author Statement: Maksym Melnychuk: Conceptualization, Supervision, Investigation, and Writing- original draft; **Oleksii Petrov:** Conceptualization, Supervision, Investigation, and Writing- original draft;

Konstantin Torop: Conceptualization, Supervision, Investigation, and Writing- original draft; **Igor Jaki-menko:** Conceptualization, Supervision, Investigation, and Writing- original draft; **Linjun Xun:** Investigation, Data curation, and Data availability; **Husheng Zhao:** Investigation, Data curation, and Data availability.

Data Availability Statement: Not applicable.

Funding: This research was funded by own facilities.

Conflicts of Interest: The authors declare no conflict of interest. The funders had no role in the design of the study; in the collection, analyses, or interpretation of data; in the writing of the manuscript, or in the decision to publish the results.

Acknowledgments: Not applicable.

References

- Aiken, G. R., McKnight, D. M., Wershaw, R. L., & MacCarthy, P. (Eds.). (1985). *Humic substances in soil, sediment and water: Geochemistry and isolation*. John Wiley & Sons.
- Chen, M., Jin, X., Wang, Y., Wang, X., Cai, Z., & Sun, X. (2020). Enhanced removal of humic substances in effluent organic matter from a leachate treatment system via biological upgradation of molecular structure. *Environmental Technology*, 43(23), 3620–3630. <https://doi.org/10.1080/09593330.2021.1929505>
- Cheng, G., Niu, Z., Zhang, C., Zhang, X., & Li, X. (2019). Extraction of humic acid from lignite by KOH-Hydrothermal method. *Applied Science*, 9(7), 1356. <https://doi.org/10.3390/app9071356>
- Cihlár, Z., Vojtová, L., Conte, P., Nasir, S., & Kučerik, J. (2014). Hydration and water holding properties of cross-linked lignite humic acids. *Geoderma*, 230–231, 151–160. <https://doi.org/10.1016/j.geoderma.2014.04.018>
- Cui, T., Li, Z., & Wang, S. (2017). Effects of in-situ straw decomposition on composition of humus and structure of humic acid at different soil depths. *Journal of Soils Sediments*, 17, 2391–2399. <https://doi.org/10.1007/s11368-017-1704-6>
- da Silva, M. S. R. D. A., Huertas Tavares, O. C., Ribeiro, T. G., da Silva, Camilla S. R. D. A., da Silva, Carolina S. R. D. A., García-Mina J. M., Baldani, V. L. D., García, A. C., Berbara, R. L. L., & Jesus, E. C. (2021). Humic acids enrich the plant microbiota with bacterial candidates for the suppression of pathogens. *Applied Soil Ecology*, 168, 104146. <https://doi.org/10.1016/j.apsoil.2021.104146>
- de Melo, B. A. G., Lopes Motta, F., & Andrade Santana, M. H. (2016). Humic acids: Structural properties and multiple functionalities for novel technological developments. *Materials Science and Engineering: C*, 62, 967–974. <https://doi.org/10.1016/j.msec.2015.12.001>
- Drosos, M., Jerzykiewicz, M., Louloudi, M., & Deligiannakis, Y. (2011). Progress towards synthetic modelling of humic acid: Peering into the physicochemical polymerization mechanism. *Colloids and Surfaces A: Physicochemical and Engineering Aspects*, 389(1–3), 254–265. <https://doi.org/10.1016/j.colsurfa.2011.08.016>
- Gairhe, S., Timsina, K. P., Ghimire, Y. N., Lamichhane, J., Subedi, S., & Shrestha, J. (2021). Production and distribution system of maize seed in Nepal. *Heliyon*, 7(4), Article e06775. <https://doi.org/10.1016/j.heliyon.2021.e06775>
- Hassan, A., Ullah, A., Hammad, Jan, Z., Zakirullah, Khan, A., Raza, M., & Shah, Z. (2023). Effect of humic acid and bread yeast application on the vegetative, yield and qualitative attributes of tomato (*Lycopersicon esculentum L.*). *Pure and Applied Biology*, 12(1), 677–682. <https://doi.org/10.19045/bspab.2023.120069>
- Jaing, T., Han, G. H., Zhang, Y. B., Huang, Y. F., Li, G. H., Guo, Y. F., & Yang, Y. B. (2011). Improving extraction yield of humic substances from lignite with anthraquinone in alkaline solution. *Journal of Central South University of Technology*, 18, 68–72. <https://doi.org/10.1007/s11771-011-0660-3>
- Karčauskienė, D., Repšienė, R., Ambrazaitienė, D., Mockevičienė, I., Šiaudinis, G., & Skuodienė, R. (2019). A complex assessment of mineral fertilizers with humic substances in an agroecosystem of acid soil. *Zemdirbyste-Agriculture*, 106(4), 307–314. <https://doi.org/10.13080/z-a.2019.106.039>
- Khalate, A. M., Sonkamble, A. M., Tayade, V. D., Wagh, A. P., & Jadhao, S. D. (2023). Effect of integrated nutrient management and foliar spray of humic acid on growth, yield and quality of Brinjal (*Solanum melongena L.*). *The Pharma Innovation Journal*, 12(5), 3373–3776. <https://www.thepharmajournal.com/archives/2023/vol12issue5/PartAN/12-5-577-887.pdf>
- Khemakhem, M., Papadimitriou, V., Sotiroudis, G., Zoumpoulakis, P., Arbez-Gindre, C., Bouzouita, N., & Sotiroudis, T. G. (2016). Melanin and humic acid-like polymer complex from olive mill waste waters. Part I. Isolation and characterization. *Food Chemistry*, 203, 540–547. <https://doi.org/10.1016/j.foodchem.2016.01.110>
- Makan, A. (2021). *Humic Substance*. Intech Open. <https://doi.org/10.5772/intechopen.92966>
- Nardi, S., Schiavon, M., Muscolo, A., Pizzeghello, D., Ertani, A., Canelas, L. P., & Garcia-Mina, J. M. (2024). Editorial: Molecular characterization of humic substances and regulatory processes activated in plants, volume II. *Frontiers in Plant Science*, 15, 1413829. <https://doi.org/10.3389/fpls.2024.1413829>
- Niewes, D., Marecka, K., Braun-Giwerska, M., & Huculak-Mączka, M. (2023). Application of a modified method of humic acids extraction as an efficient process in the production of formulations for agricultural purposes. *Polish Journal of Chemical Technology*, 25(3), 31–39. <https://doi.org/10.2478/pjct-2023-0022>
- Novák, J., Kozler, J., Janoš, P., Čezíková, J., Tokarová, V., & Madronová, L. (2001). Humic acids from coals of the North-Bohemian coal field: I. Preparation and characterisation. *Reactive and Functional Polymers*, 47(2), 101–109. [https://doi.org/10.1016/S1381-5148\(00\)00076-6](https://doi.org/10.1016/S1381-5148(00)00076-6)
- Regulation (EU) 2019/1009 of the European Parliament and of the Council of 5 June 2019 laying down rules on the making available on the market of EU fertilising products and amending Regulations (EC) No 1069/2009 and (EC) No 1107/2009 and repealing Regulation (EC) No 2003/2003 (Text with EEA relevance). *Official Journal of the European Union*. (2019). <http://data.europa.eu/eli/reg/2019/1009/oj>
- Sarlaki, E., Paghaleh, A. S., Kianmehr, M. H., & Vakilian, K. A. (2019). Extraction and purification of humic acids from lignite wastes using alkaline treatment and membrane ultrafiltration. *Journal of Cleaner Production*, 235, 712–723. <https://doi.org/10.1016/j.jclepro.2019.07.028>
- Sevast'yanov, V. P., Petrov, A. I., Rabenko, L. I., Torop, K. N., & Vary'gin, V. N. (2015). *Method for comprehensively processing brown coal and leonardite into humic fertilizers and preparations and into fuel briquettes, and mechanochemical reactor for processing*

- highly-viscous media* (WIPO Patent WO No. 2015163785A1). World Intellectual Property Organization. <https://patentscope.wipo.int/search/en/detail.jsf?docId=WO2015163785>
- Stefanova, M., Gonsalvesh, L., Marinov, S., Czech, J., Carleer, R., & Yperman, J. (2016). Reductive pyrolysis of Miocene-aged lignite humic acids, Bulgaria. *Fuel*, *165*, 324–330. <https://doi.org/10.1016/j.fuel.2015.10.032>
- Stevenson, F. J. (1994). *Humus Chemistry: Genesis, Composition, Reactions* (2nd ed.). John Wiley & Sons. <https://archive.org/details/humuschemistryge0000stev>
- Tiwari, J., Ramanathan, A. L., Baudh, K., & Korstad, J. (2023). Humic substances: Structure, function and benefits for agroecosystems—A review. *Pedosphere*, *33*(2), 237–249. <https://doi.org/10.1016/j.pedsph.2022.07.008>
- Yan, S., Zhang, N., Li, J., Wang, Y., Liu, Y., Cao, M., & Yan, Q. (2021). Characterization of humic acids from original coal and its oxidization production. *Scientific Reports*, *11*, 15381. <https://doi.org/10.1038/s41598-021-94949-0>
- Vašková, J., Stupák, M., Vidová Ugurbaş, M., Žatko, D., & Vaško, L. (2023). Therapeutic efficiency of humic acids in intoxications. *Life*, *13*(4), 971. <https://doi.org/10.3390/life13040971>

Disclaimer: The views, statements, and data presented in *Agricultural & Rural Studies (A&R)* reflect solely the perspectives of the individual authors and contributors, and do not represent the official positions of SCC Press and/or the editorial team. SCC Press and/or the editorial team assume no liability for any harm, injury, or damage to persons or property arising from the ideas, methodologies, instructions, or products referenced herein.